

---

# VACUFLUSH® STATUS PANEL

---

## PRODUCT GUIDE

---



**Dometic Corporation • Sanitation Systems**  
13128 State Rt. 226, P.O. Box 38  
Big Prairie, OH 44611-0038 USA  
SeaLand Product Hotline 1-800-321-9886  
(8:00 a.m. - 5:00 p.m. ET)

---

---

## TABLE OF CONTENTS

---

Safety Instructions	2	Dimensional Specifications	4
Electrical Specifications	2	Parts List	4
Product Features	2	Control Panel Mounting Template	5
Installation Instructions	3	Wiring Diagrams	5, 7
How to Use	3	Warranty Information	8

---

## SAFETY INSTRUCTIONS

---

**WARNING:** When using this device, always exercise basic safety precautions including the following:

- Read all instructions before use or installation.
- Never connect this device to any electrical circuit with other than 12, 24 or 32 volt Direct Current or exceed the amperage draw specified below.
- Never install, use or service any component of this device in an atmosphere with potentially flammable or explosive vapors.

---

## SPECIFICATIONS

---

**Product Name:**

VacuFlush Status Panel

**Shipping Information:**

Carton Size: 6 in x 6 in x 4 in (15.2 cm x 15.2 cm x 10.2 cm)

**Electrical:**

Current and Wattage per Indicator Light

	12 VDC	24 VDC	32 VDC
<b>Amps</b>	.012 – .016	.012 – .016	.020 – .024
<b>Watts</b>	.15 – .22	.29 – .45	.64 – .86

Magnetic, manual reset circuit breaker

SIZE	F.L. AMPS	TRIP AMPS	MAX VDC
5 Amp	5	6.75	32
10 Amp	10	13.5	32

Maximum wire size per terminal block pin = 12 gauge

---

## PRODUCT FEATURES:

---

- Continuously monitors status of vacuum for proper operation.
- Magnetic circuit breaker designed to protect the vacuum pump from damage.
- Allows the boater to shut the system down during the night.
- Deluxe panel complements bathroom decor.
- Indicates loss of electrical power or system power off.

---

## INSTALLATION INSTRUCTIONS

---

1. Select a mounting location away from direct contact with water and oil. Dry locations in the head, salon or galley are most desirable.
2. Confirm clearances for the panel behind walls and bulkheads.
3. Cut out mounting hole for control panel. (See template on page 5 for cut out and hole locations)
4. Do not mount panel housing until wiring is routed and secured.
5. Route wires using the wiring diagram on pages 5 & 7.
6. Mount panel housing with the (4) #6 x 1" long black oval head screws provided.
7. Insert the (2) small tabs on the left side of the face plate into the housing and snap the large tab on the right side of the face plate into the housing to secure it.

---

## HOW TO USE THE VACUFLUSH STATUS PANEL

---

Under normal operating conditions the red lamp will light after each flush until the pump recharges the vacuum to proper operating level then the green lamp will light.

If there is constant green light to red light cycling between flushes it may indicate a leak in the vacuum system. The vacuum pump will normally operate automatically every so often to recharge the vacuum,.

A continuous red light indicates an extended loss in vacuum as a result of a blockage, pump failure or massive vacuum leak. **TURN OFF THE SYSTEM AND REPAIR AS SOON AS POSSIBLE.**

If the red light seems to stay on longer than when the system was originally installed, it is probably time to replace the duckbill valves in the vacuum pump.

If there is no vacuum in the toilet and the green light is on, a blockage has probably occurred between the toilet bowl and the vacuum tank.

If there is no vacuum present in the toilet after several minutes, it may indicate a blockage at the outlet of the vacuum tank or inlet of the vacuum pump.

# DIMENSIONAL SPECIFICATIONS

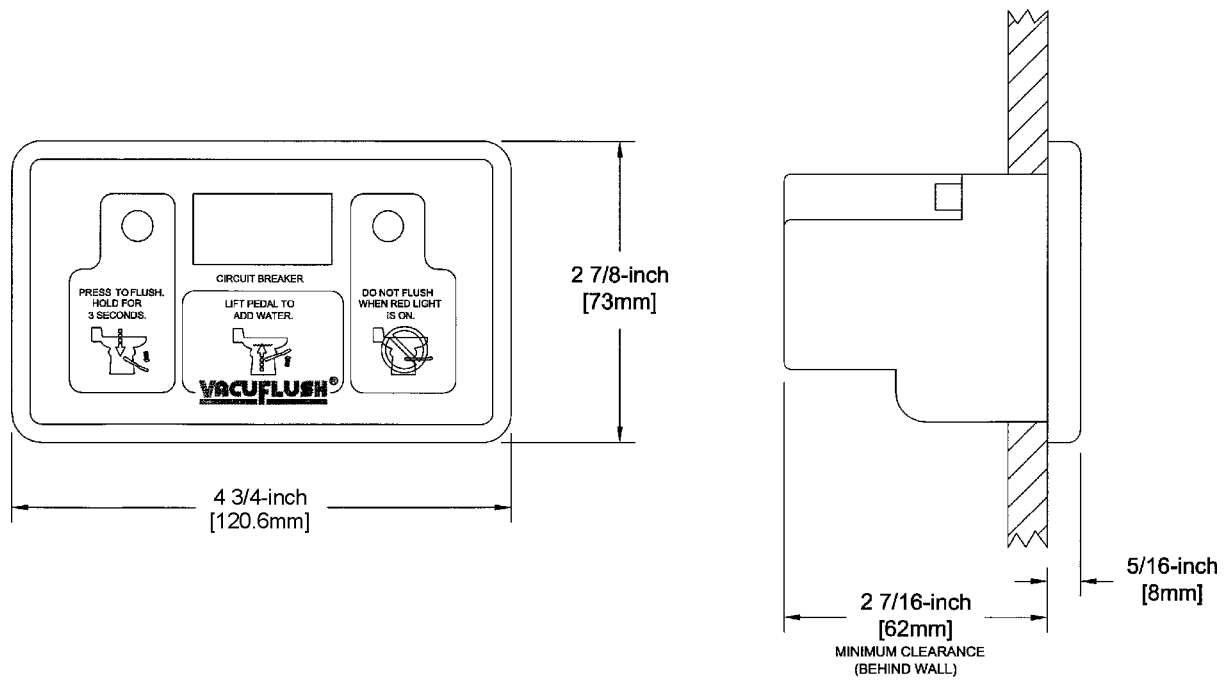

# PARTS LIST

Item	Part No.	Description
1	600342400	VacuFlush Status Panel Housing
2	600340471	#6 x 1" Long Oval Phillips Head Screw
3	600343786	VacuFlush Status Panel Face Plate
4	600342493	Red Lens
5	600342652	Circuit Breaker, 12VDC 10 amp
6	600342495	Green Lens
7	600340488	#6 x 3/8" Long Pan Phillips Head Screw
8	385310636	VacuFlush Status Panel, 12 VDC
	385310637	VacuFlush Status Panel, 24/32 VDC

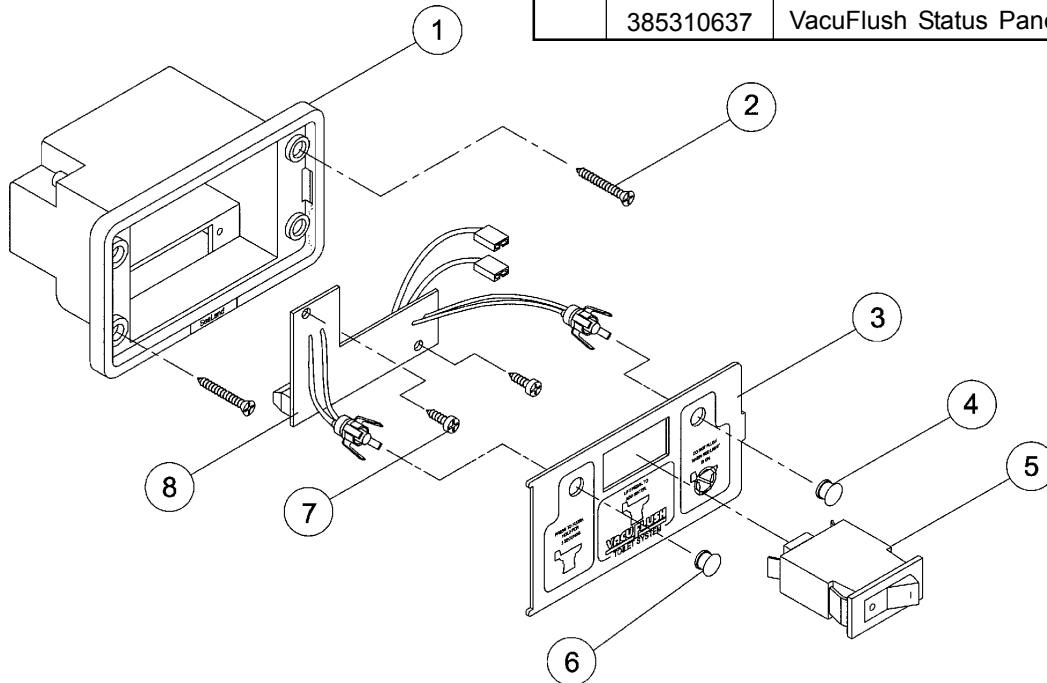

# CONTROL PANEL MOUNTING TEMPLATE

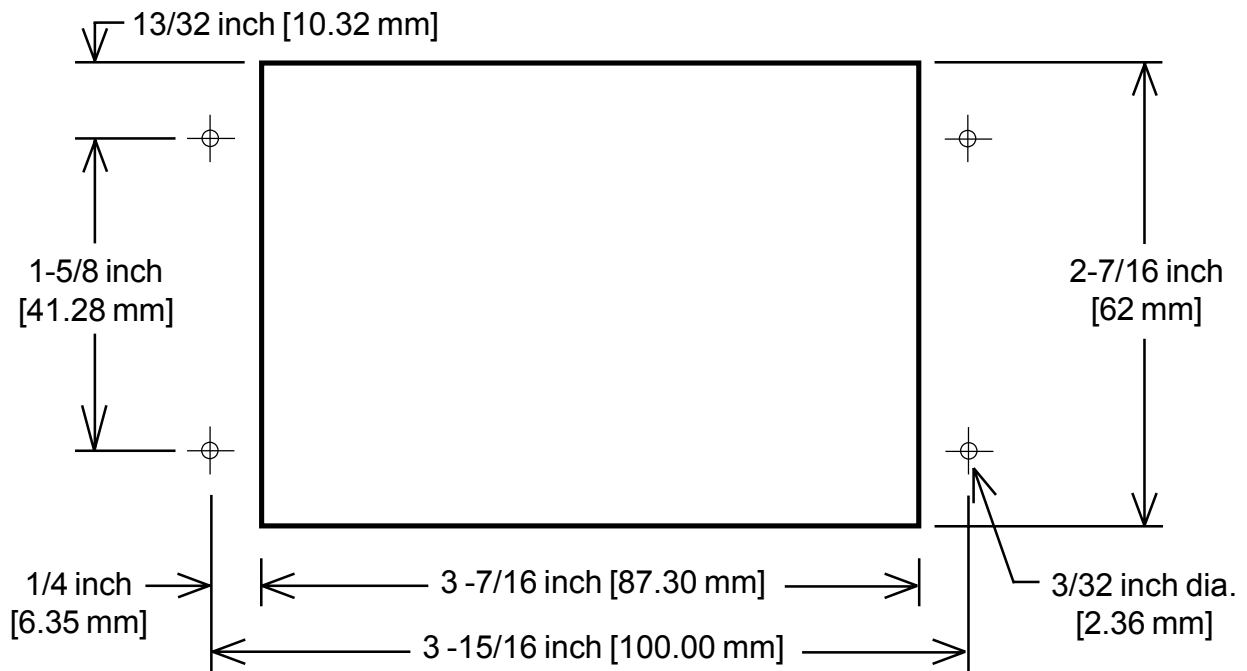

# WIRING DIAGRAM

VacuFlush Status Panel with Vacuum Tank & Vacuum Pump

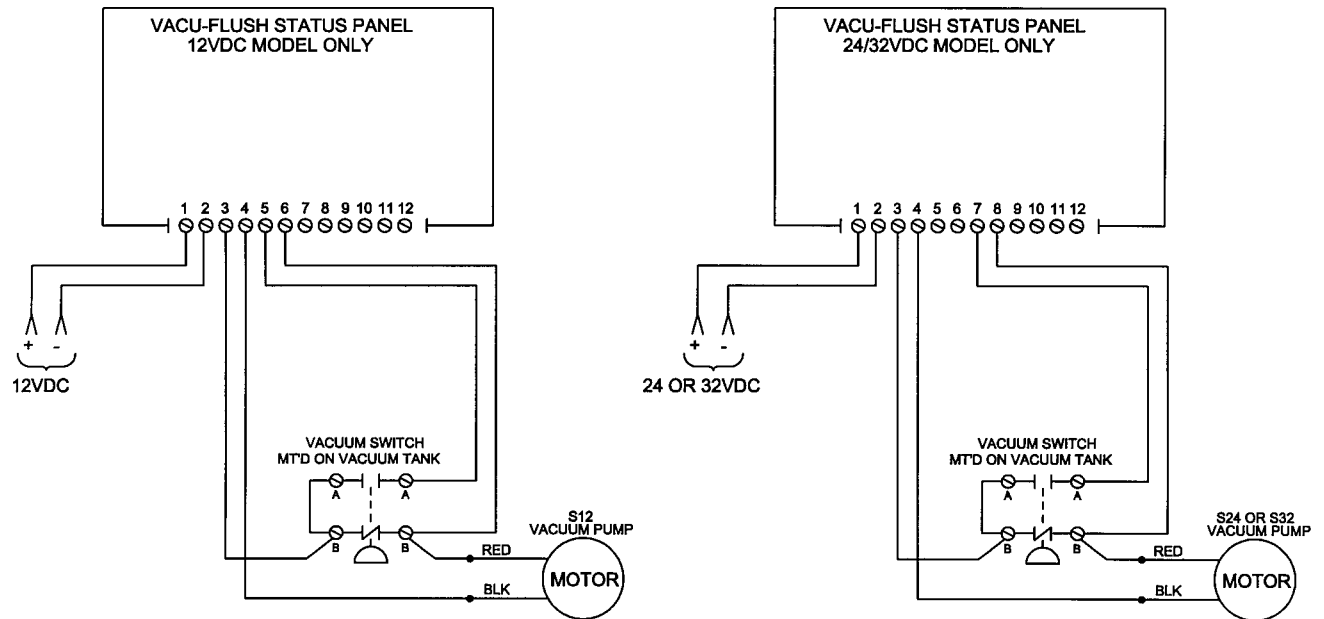

This page intentionally left blank.



---

# MANUFACTURER'S ONE-YEAR LIMITED WARRANTY

---

Dometic Corporation warrants, to the original purchaser only, that this product, if used for personal, family or household purposes, is free from defects in material and workmanship for a period of one year from the date of purchase.

If this Dometic product is placed in commercial or business use, it will be warranted, to the original purchaser only, to be free of defects in material and workmanship for a period of ninety (90) days from the date of purchase.

Dometic reserves the right to replace or repair any part of this product that proves, upon inspection by Dometic, to be defective in material or workmanship. All labor and transportation costs or charges incidental to warranty service are to be borne by the purchaser-user.

## EXCLUSIONS

IN NO EVENT SHALL **DOMETIC** BE LIABLE FOR INCIDENTAL OR CONSEQUENTIAL DAMAGES, FOR DAMAGES RESULTING FROM IMPROPER INSTALLATION, OR FOR DAMAGES CAUSED BY NEGLIGENCE, ABUSE, ALTERATION OR USE OF UNAUTHORIZED COMPONENTS. ALL IMPLIED WARRANTIES, INCLUDING ANY IMPLIED WARRANTY OF MERCHANTABILITY OR FITNESS FOR ANY PARTICULAR PURPOSE, ARE LIMITED TO A PERIOD OF ONE YEAR FROM DATE OF PURCHASE.

## IMPLIED WARRANTIES

No person is authorized to change, add to, or create any warranty or obligation other than that set forth herein.

Implied warranties, including those of merchantability and fitness for a particular purpose, are limited to one (1) year from the date of purchase for products used for personal, family or household purposes, and ninety (90) days from the date of purchase for products placed in commercial or business use.

## OTHER RIGHTS

Some states do not allow limitations on the duration of an implied warranty and some states do not allow exclusions or limitations regarding incidental or consequential damages; so, the above limitations may not apply to you. This warranty gives you specific legal rights, and you may have other rights which vary from state to state.

To obtain warranty service, first contact your local dealer from whom you purchased this product.



**Dometic Corporation • Sanitation Systems**  
13128 State Rt. 226, P.O. Box 38  
Big Prairie, OH 44611-0038 USA  
SeaLand Product Hotline 1-800-321-9886  
(8:00 a.m. - 5:00 p.m. ET)

® Registered; ™ Trademark of Dometic Corporation  
© Dometic Corporation